

tenon  
PARTITIONS



flexplus

versatility through simplicity



flexplus  
tenon



flexplus  
at a glance

BOARD  
ROOMS

EXECUTIVE  
OFFICE SUITES

RECEPTION  
AREAS

CONFERENCE  
SUITES

GENERAL  
OFFICE

CLEAN  
ROOM

LIGHT  
INDUSTRIAL

**Areas of use**



**Fire performance**

Solid modules - standard construction is non fire rated. Monobloc construction can provide 30 min fire rating to BS476 part 22.

Glazed modules - fire rated glazing is not available.

Door modules - standard construction is non fire rated. Solid doors within monobloc construction can provide 30 min fire rating to BS476 part 22.

**Acoustic performance**

Solid modules - standard construction - up to 29dB.

Glazed modules - standard construction - up to 29dB.

Door modules - standard cellular core - up to 20dB.

**Construction Options**

Solid modules - standard construction from plasterboard honeycomb panels or hardboard faced flaxcore panels. Many other finishes available.

Glazed modules - all elevation types incorporating centre single, offset single and double glazing and venetian blinds.

Door modules - standard frames are fitted with 1981 x 838 x 44mm doors. Frames will also accept most door types including glass & aluminium.

**Max Construction Heights**

Solid modules - standard construction - up to 3600mm. Specialist sections can be used to reach heights of 6000mm.

Glazed modules - maximum recommended height using standard sections - 3000mm. Specialist sections can be used to reach heights of 6000mm.



## Versatility

**Tenon Flexplus** is a fully demountable and re-locatable multi-purpose aluminium partition system that is simple and quick to install.

Flexplus is based on a module width of 1200mm, offering the flexibility to allow changes in layout whilst minimising wastage.

The options available, not only in construction methods, but also with section, panel, door type and joint details, make it ideal for a variety of locations.

The system is constructed using aluminium channel and upright sections, together with aluminium or plastic glazing beads and a choice of three door frame profiles.

Solid construction is achieved with the use of plasterboard faced honeycomb or hardboard/laminate faced flexcore panels.

*All Flexplus components are readily available throughout the UK and Ireland offering a practical partition system that combines fastrack construction with aesthetics and flexibility.*



## Flexibility

Tenon Flexplus offers a choice of glazing details. Single, single offset and double glazing sections are available to provide options to suit both design and cost constraints. 25mm and 15mm venetian blinds are available in a wide range of colours and are easily accommodated within the system with the use of switch posts.

Doors are available in natural wood finishes, including Ash, Koto, Oak, Cherry, Maple, Beech and Sapele and can include any shape or size of vision panel or lipping.

To compliment Flexplus, the NEXUS range of ironmongery offers a wide choice of door furniture in a variety of finishes.



*For more information or advice on this system's performance please contact the Tenon Technical Department.*



## Adaptability

Flexplus can provide **30 minute fire rating** to BS476 Part 22 (1987) when using flexcore laminated panels and solid core doors. The panels are supplied with bevelled edges and are installed in monobloc fashion.

If you require fire rated glazing, please contact the Tenon Technical Department. Base section detailing can include for traditional laminate face fixed skirting or aluminium base and clip-in skirting for cable management.

The range of sections available, allows construction of partitions from barrier height up to 6000mm. All aluminium sections are available in the standard range of RAL and BS colours, to compliment any corporate colour scheme.

*Flexplus is durable and flexible in application. Designed for use in general office areas.*



Tenon Flexplus is a demountable and re-locatable modular partition system that is ideal for general office areas. Quick and easy to install, it provides a cost effective solution for locations where acoustic and fire performance are not required.

A number of construction methods are possible and by using the full range of panels available, the system is also suitable for both light industrial and basic 'cleanroom' installations.

**Components**

The major components of the system are an aluminium reversible head channel, upright and junction posts together with a choice of base details.

**Size**

Tenon Flexplus is based on a module size of 1200mm wide by 54mm thick. With the use of specialist sections, the system can be constructed up to heights of 6000mm.

**Panels**

Flexplus may be fitted with various panel types to suit the chosen specification. Honeycomb and flaxcore panels are supplied with square edges and are fitted within the system's upright posts. In addition to laminate facings, steel and aluminium can be bonded to a variety of cores for use in light industrial or heavy traffic areas.

If monobloc construction is specified, panels are supplied with bevelled and rebated edges.

*If cable management is required at the base of the partition, aluminium base section P97 is recommended for use in conjunction with clip in skirting profile P98.*

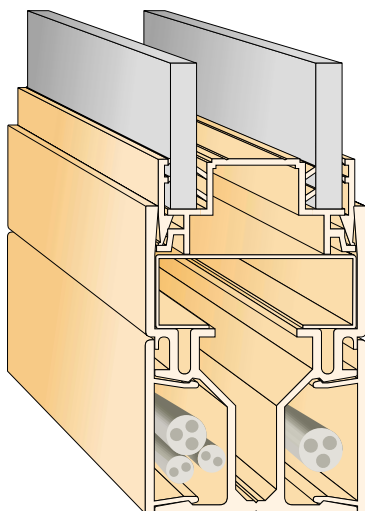

**Appearance**

Aluminium profiles are supplied from stock in a silver anodised finish, Grade AA5, but may be powder coated in a range of twelve standard colours:

RAL 5010 Gentian Blue	RAL 9010 Pure White
RAL 5012 Light Blue	RAL9016 Traffic White
RAL 6005 Moss Green	BS:00 A 05 Light Grey
RAL 7011 Iron Grey	BS:04 E 53 Geranium Red
RAL 9005 Jet Black	BS:08 B 15 Magnolia
RAL 9006 Silver	BS:08 B 29 Van Dyke Brown

Standard BS 4800 and RAL colours not included in the above list are available, however, these may be subject to longer lead times and additional costs.

Plasterboard faced honeycomb and hardboard faced flaxcore panels can be supplied unfinished for decoration on site or be factory finished with the vinyl or laminate or your choice.

**Glazing**

Glazing is carried out with the use of pre-bracketed transoms and a choice of plastic or aluminium glazing sections, allowing for centre single, single offset and double glazing. Glass between a thickness of 6mm and 6.4mm can be accommodated within the system.

All glass fitted within the system should comply with Approved Document N of The Building Regulations 1993. Part N1 covers glazed areas of critical locations with regard to safety. This includes all full height partitions, half glazed partitions adjacent to doors and vision panels in doors. Part N2 covers manifestation of glazing in critical locations where people may collide with it.

A full glazing supply service is available for all Flexplus partitions. Please contact your local Tenon stockist for details.

**Venetian Blinds**

Flexplus double and single offset glazing sections allow 15mm and 25mm venetian blinds to be fitted within the system. Where blinds are specified, it is recommended that a demountable blind post is used to allow the remote control knob to be fitted.

Please contact your local branch for details of the service provided.

## Door Modules

Standard door frames are supplied in universal frame packs (i.e. left or right handed), with a choice of frame profile (see below), and come pre-mitred complete with pre-cut aluminium transom, factory fitted hinges, Tenon lock box and door seal. The door seal has been tested as a smoke seal and complies with the requirements of BS 476 part 31.1.

All fire rated frames, and frames to suit doors with overpanels and laminated doors will be supplied with one and a half pairs of steel hinges. In all these situations, frames should be fitted to a junction post or a strengthened upright post for added stability.

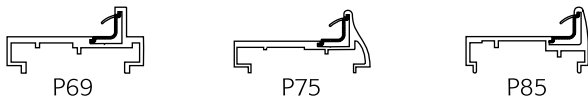

## Doors

Doors are available with veneered or laminate facings with a choice of hardwood or laminate lippings. Both cellular core and solid core doors can be supplied in standard sizes. Veneers available include Sapele, Cherry, Oak, Ash, Koto, Maple and Beech .

The full range of Tenon joinery options are available including vision panels, relipping etc.

## Fire

Tenon Flexplus has been tested at The Building Test Centre at East Leake and meets the requirements of Fire and Building Control Officers. All tests were carried out in accordance with BS 476 part 22 (1987). **The test results allow us to offer 30 minute fire rating on:-**

<b>Doors</b>	Single Leaf Leaf and Overpanel
<b>Solid Panels</b>	Laminate and hardboard faced flaxcore panels using Class 1 materials and fire rated adhesive.
<b>Glazing</b>	Not currently available with Tenon <b>Flexplus</b> .

If fire rated glazing is required, Tenon Fire & Sound should be specified. For further information please contact the Tenon Technical Department.

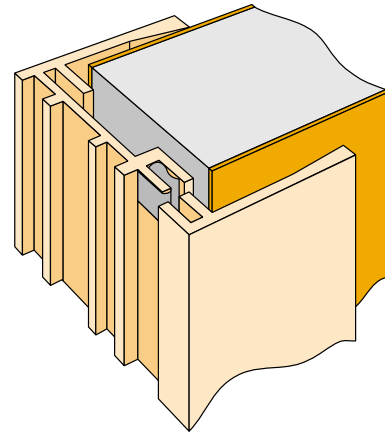

*Wherever solid or part glazed modules abut a wall, the use of clip fit wall abutment section P92/P93 is recommended to allow the fitting of the last panel.*

## Sound

Tenon Flexplus has been tested at the Building Test Centre in accordance with B.S. 2750: Part 3 1980 :ISO 140/111 - 1978 in accordance with BS821: part 1: 1984: ISO 717/1 - 1982(Rw)

Weighted Sound Reduction Index Rw

<b>Test 1</b>	Solid partition constructed with 46mm plasterboard faced honeycomb panels.	29dB (Rw)
<b>Test 2</b>	Solid partition constructed with 46mm hardboard faced flaxcore panels.	27dB (Rw)
<b>Test 3</b>	Half Glazed partition constructed using 46mm hardwood faced flaxcore panels and two panes of 6.4mm laminated glass.	29dB (Rw)

It should be noted that all the above results were obtained under laboratory test conditions. The expected level of performance should take into account the type of ceiling, ducting, flooring etc present. The leakage of sound through poorly insulated parts of the partition will have a significant effect on the level of sound attenuation possible.

## Product Maintenance

All elements of the Flexplus system may be cleaned using a solution of mild detergent in warm water and a soft cloth or sponge. The frequency of cleaning will depend on the environment the partition is situated in and the level to which the surface has been soiled.

When cleaning vinyl faced plasterboard, avoid an accumulation of water at skirting level as this may lead to delamination of the vinyl covering.

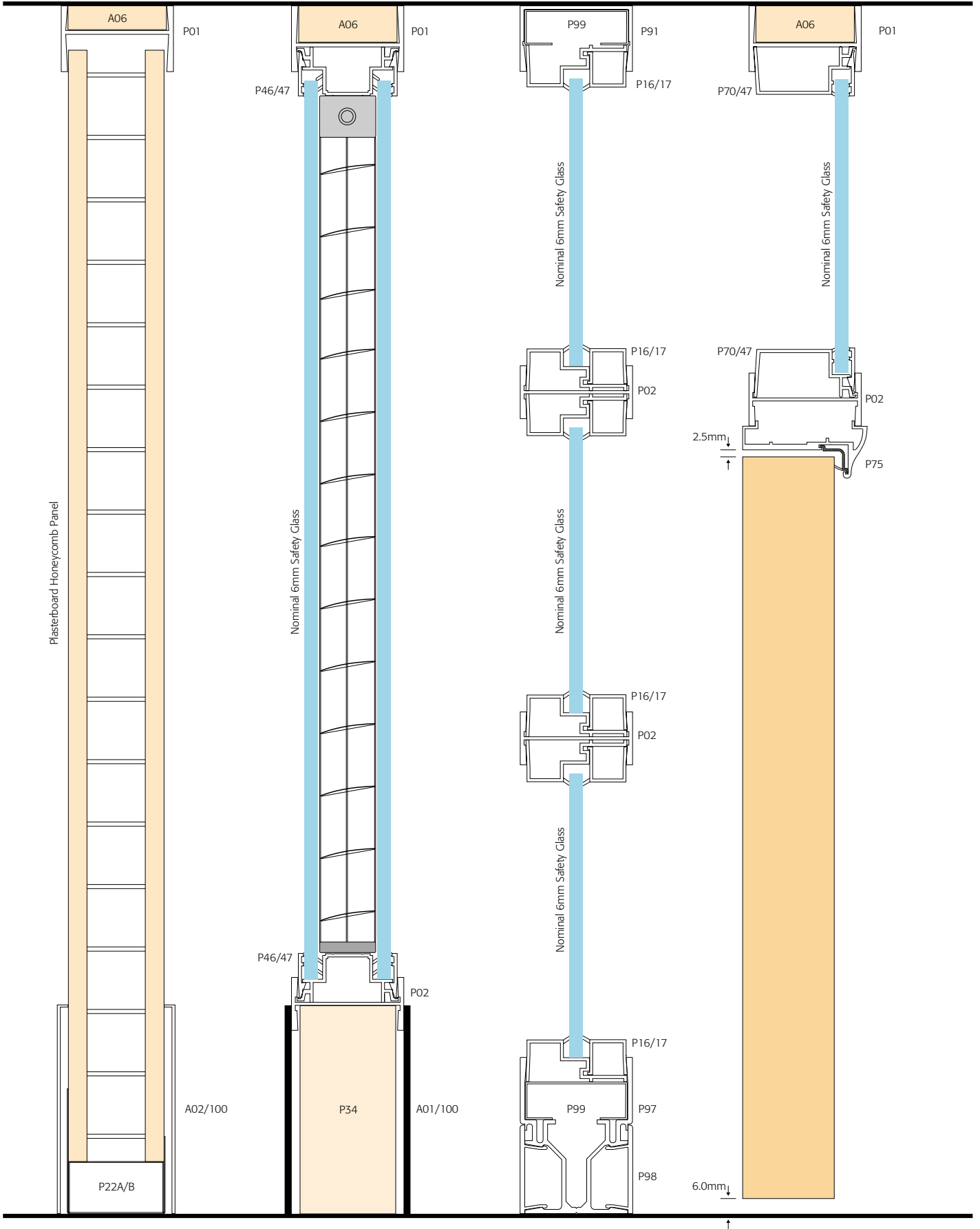

flexplus - elevations



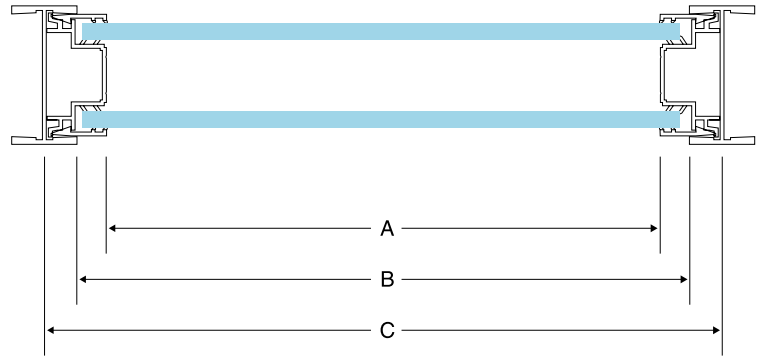
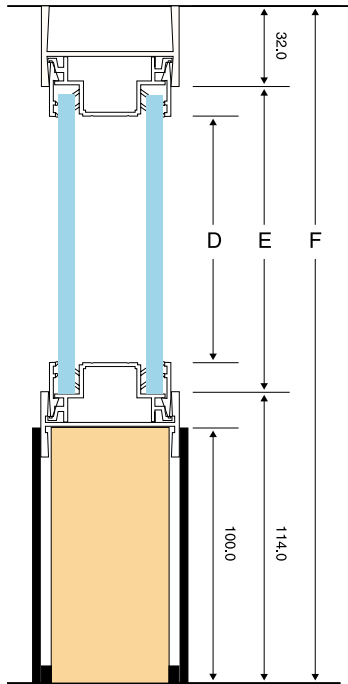

	WIDTH			HEIGHT	
	METRIC			METRIC	
<b>DIM A</b>	1155mm		<b>DIM D</b>	2529mm	
<b>DIM B</b>	1180mm	GLASS APERTURE DIMENSION	<b>DIM E</b>	2554mm	
<b>DIM C</b>	1204mm	BLIND APERTURE DIMENSION	<b>DIM F</b>	2700mm	

### flexplus - glazing setting out details

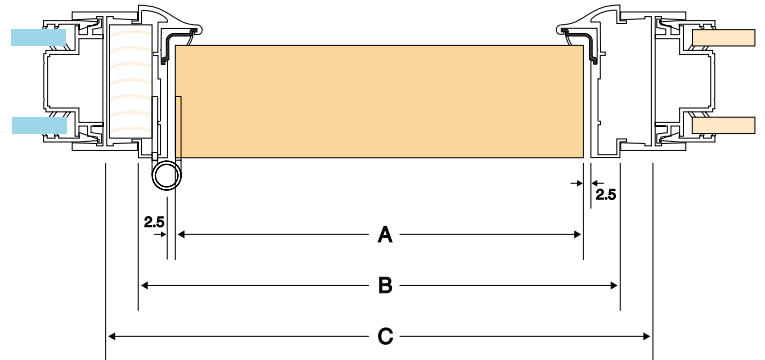
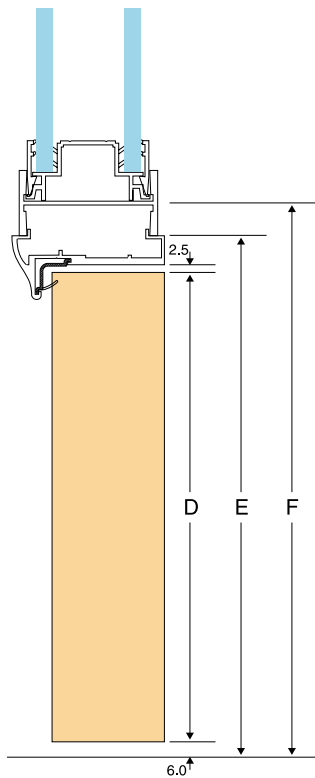

	SINGLE		DOUBLE	
	METRIC	IMPERIAL	METRIC	IMPERIAL
<b>DIM A</b>	826mm	838mm	1652mm	1676mm
<b>DIM B</b>	856mm	868mm	1684mm	1708mm
<b>DIM C</b>	881mm	893mm	1709mm	1733mm
<b>DIM D</b>	2040mm	1981mm	2040mm	1981mm
<b>DIM E</b>	2061mm	2002mm	2061mm	2002mm
<b>DIM F</b>	2074mm	2015mm	2074mm	2015mm

### flexplus - door frame setting out details

## Section Details



**P01 ALUMINIUM REVERSIBLE HEAD CHANNEL**  
accepts glazed or solid panels at partition head.



**P91 ALUMINIUM DEEP HEAD CHANNEL**  
accepts solid panels or glazing with the inclusion of steel base and head platform (P99). Used primarily for 'monobloc' construction.



**P99 STEEL BASE AND HEAD PLATFORM**  
used to support solid panels and glazing details at both head and base partition. Use with deep head channel (P91).



**P02 ALUMINIUM UPRIGHT POST**  
equal leg section used vertically to accept solid or glazed panels. Also used as pre-cut transom (P03) for use horizontally. Use with steel angle bracket (A11).



**P04/05 ALUMINIUM SCREW FIX WALL ABUTMENT POST**  
upright post (P05) used in conjunction with screw fix flat section (P04) to enable fitting of the last panel at wall abutments.



**P92/93 ALUMINIUM CLIP FIT WALL ABUTMENT POST**  
upright post (P92) used in conjunction with clip fit section (P93) and steel clip (TF276) to enable fitting of the last panel at wall abutments. Clips should be fitted at either end and at 600mm centres.



**P06 ALUMINIUM SQUARE PROFILE 90° CORNER POST**  
square profile 90° boxed corner post. Used in conjunction with two steel angle brackets (A11).



**P07 ALUMINIUM NIBBED UPRIGHT POST**  
strengthened upright post for use in partitions over 3600mm high and up to 4200mm.



**P11 ALUMINIUM CIRCULAR UPRIGHT POST**  
used in conjunction with upright post (P02) at intersections where non standard angles are required.



**P12 ALUMINIUM SHALLOW CHANNEL**  
used in conjunction with three way section (P31) to form a four way post or angled corner post (P40) to form a 'Y' post.



**P13 ALUMINIUM HEAVY DUTY POST**  
Used as an upright post and head section for heights up to 6000mm or when stability is required within the system.



**P15 ALUMINIUM INFILL SECTION**  
Used to cover any open face on sections within the system.



**P16/17 BLACK PLASTIC SINGLE GLAZING CHAIR & BEAD**  
Accepts glass with a thickness of between 6 and 6.4 mm. Other colours are available.



**P18/19 ALUMINIUM SINGLE GLAZING CHAIR & BEAD**  
Used to match silver anodised or powder coated finishes. Will accept glass of various thicknesses depending on the size of the glazing foam used.



**P20/21 ALUMINIUM BLIND POST**  
comprising upright post (P20) and, infill section (P21). Used for the housing of venetian blind control cables and for general cable management. Use with steel clip (A24), one at each end and at 600mm centres in between.



**P31 ALUMINIUM THREE WAY POST**  
Allows for three way intersections of solid/glazed or doorframe construction. Used in conjunction with two steel angle brackets (A11).



**P34 FULL HEIGHT GLAZING PACKER**  
Used at the base of the partition in full height glazed modules below transom sections (P03) in lieu of pan & shoe (P22A/B).

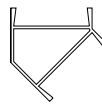

**P40 ALUMINIUM ANGLED 135° CORNER POST**  
Used to allow for solid, glazed or doorframe construction at 45° adjacent to a straight run. Used in conjunction with two steel angle brackets (A11).



**P46/47 BLACK PLASTIC DOUBLE GLAZING CHAIR & BEAD**  
Accepts glass with a thickness of between 6 and 6.4mm. Also available in white and grey.



**P70/47 BLACK PLASTIC SGL OFFSET GLAZING CHAIR & BEAD**  
Accepts glass with a thickness of between 6 and 6.4mm. Also available in white and grey.



**P69 ALUMINIUM UNIVERSAL SINGLE DOOR FRAME PACK**  
Universal (non handed) door frame pack comprising pre-cut sections milled for lock box and hinges, plastic seal, lockbox, 75mm steel hinges and pre-cut/bracketed transom.



**P75 ALUMINIUM UNIVERSAL CURVED PROFILE SINGLE DOOR FRAME PACK**  
Contents as above.



**P85 ALUMINIUM UNIVERSAL RADIUSED PROFILE SINGLE DOOR FRAME PACK**  
Contents as above.

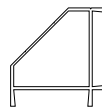

**P90 ALUMINIUM ANGLED 90° CORNER POST**  
Corner post used as an alternative to P06/P94 or in conjunction with Shallow channel P12 to create a 'Y' post. Use with two steel angle brackets (A11).

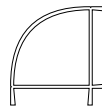

**P94 ALUMINIUM RADIUS 90° CORNER POST**  
Corner post used as an alternative to P06/P90. Used in conjunction with two steel angle brackets (A11).

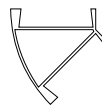

**P95 ALUMINIUM RADIUS 135° CORNER POST**  
Corner post used as an alternative to P40. Used in conjunction with two steel angle brackets (A11).

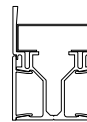

**P97/98/99 ALUMINIUM BASE SECTION & CLIP IN SKIRTING**  
Used at the base of the partition and fitted with steel platform (P99) for the support of solid panels and glazing sections. Cable management is accommodated with the use of clip fit skirting section (P98). Key component when specifying 'monobloc' construction.



**P22A/B STEEL TWO PART FLOOR PAN & SHOE**  
Used at the base of the partition on solid or part glazed modules. Two pans & shoes should be used for each 1200mm module. Provides room for cable management at floor level.



**A01 LAMINATE SKIRTING**  
face fixed skirting 75 / 100 / 150mm high. Use with 6 x 3mm black skirting foam (A07).



**A02 ALUMINIUM SKIRTING**  
face fixed skirting 75 / 100mm high. Use with 6 x 3mm black skirting foam (A07).



**A06 HEAD CHANNEL / ABUTMENT FOAM**  
used within head section (P01) on uneven ceilings and walls.



**A07 SKIRTING FOAM**  
6 x 3mm black self adhesive foam, used at the top of laminate skirting to create a shadow gap between upright posts.



**D05 PLASTERBOARD HONEYCOMB PANEL**  
comprising 9.5mm plasterboard bonded either side of a cardboard honeycomb core.



[www.cpsupplies.co.uk](http://www.cpsupplies.co.uk)

**Belfast 028 9073 1525**

Fax: 028 9045 3417  
Email: [belfast@cpsupplies.co.uk](mailto:belfast@cpsupplies.co.uk)

**Birmingham 0121 380 1600**

Fax: 0121 380 1616  
Email: [birmingham@cpsupplies.co.uk](mailto:birmingham@cpsupplies.co.uk)

**Bristol 0117 952 0633**

Fax: 0117 951 6423  
Email: [bristol@cpsupplies.co.uk](mailto:bristol@cpsupplies.co.uk)

**Cardiff 029 2049 2435**

Fax: 029 2048 0359  
Email: [cardiff@cpsupplies.co.uk](mailto:cardiff@cpsupplies.co.uk)

**Croydon 020 8684 7775**

Fax: 020 8683 3660  
Email: [croydon@cpsupplies.co.uk](mailto:croydon@cpsupplies.co.uk)

**Dublin 00 353 1 616 0919**

Fax: 00 353 1 6160788  
Email: [dublin@cpsupplies.ie](mailto:dublin@cpsupplies.ie)

**Edmonton 020 8884 3444**

Fax: 020 8884 2937  
Email: [edmonton@cpsupplies.co.uk](mailto:edmonton@cpsupplies.co.uk)

**Glasgow 0141 429 8787**

Fax: 0141 429 4147  
Email: [glasgow@cpsupplies.co.uk](mailto:glasgow@cpsupplies.co.uk)

**Kennington 020 7582 2911**

Fax: 020 7582 0271  
Email: [kennington@cpsupplies.co.uk](mailto:kennington@cpsupplies.co.uk)

**Leicester 0116 255 1585**

Fax: 0116 255 1745  
Email: [leicester@cpsupplies.co.uk](mailto:leicester@cpsupplies.co.uk)

**Manchester 0161 834 8813**

Fax: 0161 834 1825  
Email: [manchester@cpsupplies.co.uk](mailto:manchester@cpsupplies.co.uk)

**Newcastle 0191 296 2233**

Fax: 0191 296 2255  
Email: [newcastle@cpsupplies.co.uk](mailto:newcastle@cpsupplies.co.uk)

**Sheffield 0114 234 0101**

Fax: 0114 232 1684  
Email: [sheffield@cpsupplies.co.uk](mailto:sheffield@cpsupplies.co.uk)

**Southampton 023 8062 9992**

Fax: 023 8062 9993  
Email: [southampton@cpsupplies.co.uk](mailto:southampton@cpsupplies.co.uk)

**Stroud 01634 290 029**

Fax: 01634 290 888  
Email: [stroud@cpsupplies.co.uk](mailto:stroud@cpsupplies.co.uk)

**Twickenham 020 8891 5971**

Fax: 020 8892 5218  
Email: [twickenham@cpsupplies.co.uk](mailto:twickenham@cpsupplies.co.uk)



**Ceilings**  
DISTRIBUTION

[www.ceilings.co.uk](http://www.ceilings.co.uk)

**Glasgow 0141 420 3800**

Fax: 0141 420 3630  
Email: [glasgow@ceilings.co.uk](mailto:glasgow@ceilings.co.uk)

**Gateshead 0191 482 4211**

Fax: 0191 482 3500  
Email: [gateshead@ceilings.co.uk](mailto:gateshead@ceilings.co.uk)

**Warrington 01925 635 405**

Fax: 01925 628 531  
Email: [warrington@ceilings.co.uk](mailto:warrington@ceilings.co.uk)

**Manchester 0161 877 1144**

Fax: 0161 877 1155  
Email: [manchester@ceilings.co.uk](mailto:manchester@ceilings.co.uk)

**Leeds 0113 270 0333**

Fax: 0113 270 2839  
Email: [leeds@ceilings.co.uk](mailto:leeds@ceilings.co.uk)

**Sheffield 0114 276 5764**

Fax: 0114 276 2113  
Email: [sheffield@ceilings.co.uk](mailto:sheffield@ceilings.co.uk)

**Birmingham 0121 565 5700**

Fax: 0121 558 3233  
Email: [birmingham@ceilings.co.uk](mailto:birmingham@ceilings.co.uk)

**Bristol 0117 977 7377**

Fax: 0117 972 1192  
Email: [bristol@ceilings.co.uk](mailto:bristol@ceilings.co.uk)

**Exeter 01392 281 950**

Fax: 01392 281 960  
Email: [exeter@ceilings.co.uk](mailto:exeter@ceilings.co.uk)

**Bedford 01234 216696**

Fax: 01234 343584  
Email: [bedford@ceilings.co.uk](mailto:bedford@ceilings.co.uk)

**East London 020 8523 2167**

Fax: 020 8527 0606  
Email: [eastlondon@ceilings.co.uk](mailto:eastlondon@ceilings.co.uk)

**Hayes 020 8848 3248**

Fax: 020 8561 3483  
Email: [hayes@ceilings.co.uk](mailto:hayes@ceilings.co.uk)

[www.tenonpartitions.co.uk](http://www.tenonpartitions.co.uk)

For further information on Flexplus or any other products in the Tenon range, please contact:



**tenon**  
PARTITIONS

Flexplus is only one of the systems that forms the Tenon range. Other products in the range include:



fire & sound



washrooms



ovation



operable walls



scion



vitrage



wall store



accessories

A product of CPD Distribution plc  
Hillsborough Works, Langsett Road, Sheffield S6 2LW  
Tel: 0114 231 8030 Fax: 0114 231 8031



© Copyright and Design right. CPD Distribution plc 2002 Flexplus is a Registered Trademark of CPD Distribution plc.

